

Test: Primary 4 Science (Term 3) - Nan Hua

Points: 81 points

Name: _____

Score: _____

Date: _____

Signature: _____

Select multiple choice answers with a cross or tick:

Only select one answer

Can select multiple answers

Question 1 of 62

Primary 4 Science (Term 3) 2 pts

For each question, from 1 to 6, four options are given. One of them is correct.

The leaves of the mimosa plant close when a finger touches the leaves.



This shows that the mimosa plant is a living thing because it can _____.

-
- A) grow
 - B) move
 - C) respond
 - D) reproduce

Study the diagram below.



Which one of the following is a living thing?

- A) sun
- B) plant
- C) water
- D) watering can

The diagram below shows a hammer hitting a nail.

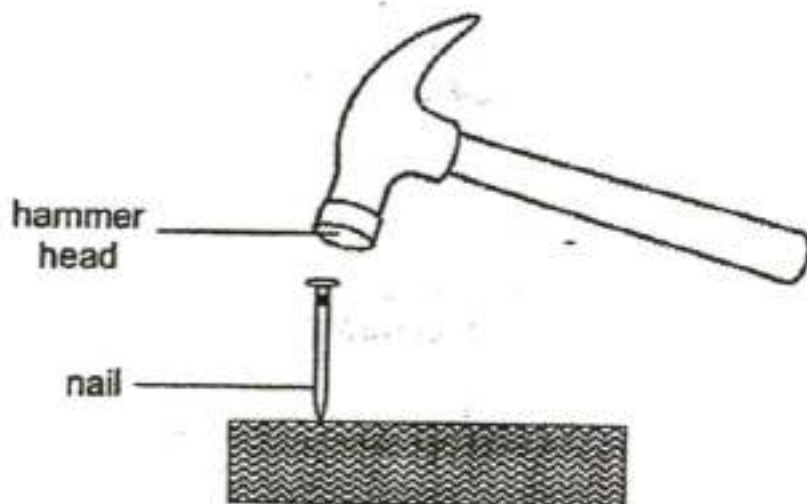

Steel is used to make the hammer head because steel _____.

- A) is shiny
- B) is strong
- C) is flexible
- D) is able to sink in water

The diagram below shows a plant.

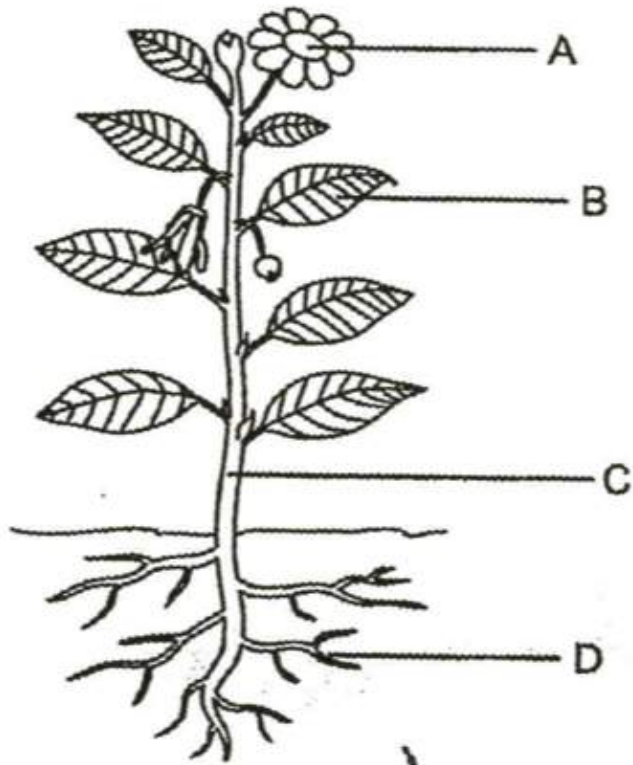

Which part, A, B, C or D, makes food for the plant?

-
- A) A
 - B) B
 - C) C
 - D) D

In which part of the digestive system is water absorbed into the blood?

(1)



Gullet

(2)



Stomach

(3)



Small intestine

(4)



Large intestine

-
- A) 1
- B) 2
- C) 3
- D) 4

In which one of the following will the two magnets push each other away?

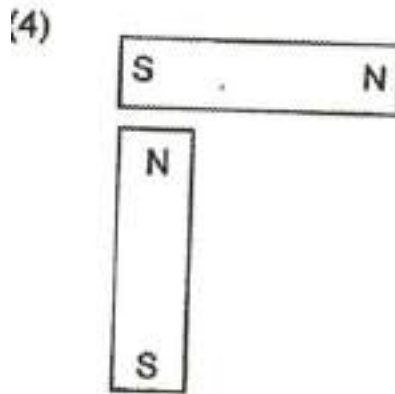
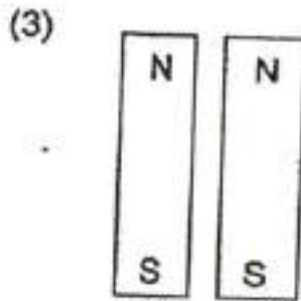
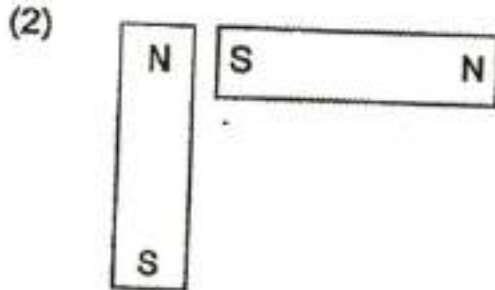
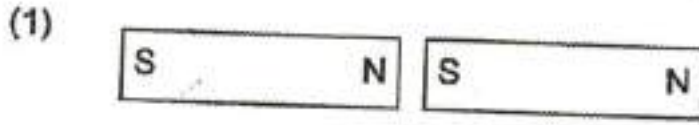

-
- A) 1
 - B) 2
 - C) 3
 - D) 4

The set-up below shows light shining on a metal cube.



torch

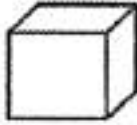

metal cube



screen

Which one of the following would likely be seen on the screen?

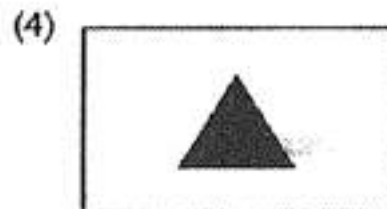
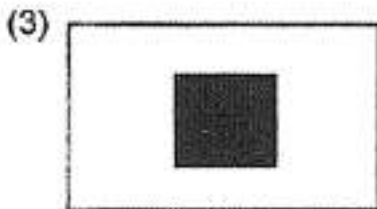
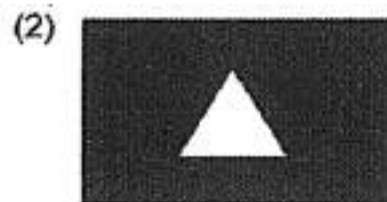
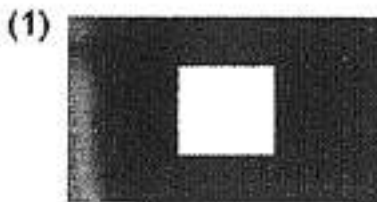

- A) 1
 B) 2
 C) 3
 D) 4

Which one of the following is not a source of heat?

- A) the sun
 B) a lighted bulb
 C) a candle flame
 D) a woollen sweater

The diagram below shows the life cycle of a living thing.

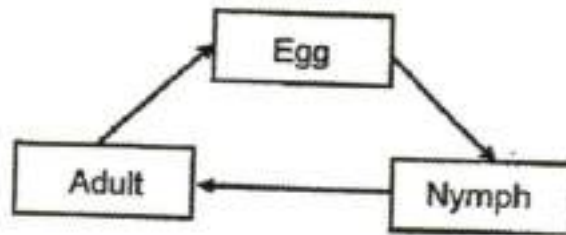

Which one of the living things goes through the same life cycle as shown above?

- A) chicken
- B) mosquito
- C) cockroach
- D) rose plant

Which one of the following properties is true for both air and milk?

- A) they can be seen
- B) they take up space
- C) they have fixed shapes
- D) they have fixed volumes

The diagram below shows the set-ups of an experiment to find out what condition(s) affect the survival of grasshoppers. After a few days, the grasshopper in Jar A died, but the grasshopper in Jar B was alive.

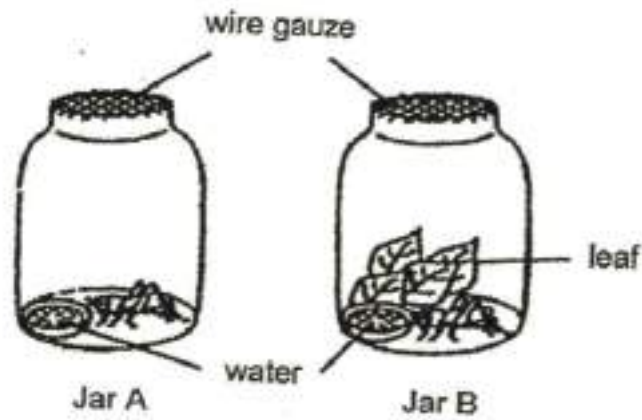

What can be concluded from this experiment only?

- A) Air is needed for the grasshopper to stay alive
- B) food is needed for the grasshopper to stay alive
- C) water is needed for the grasshopper to stay alive
- D) air, food and water is needed for the grasshopper to stay alive

Study the flowchart below carefully.

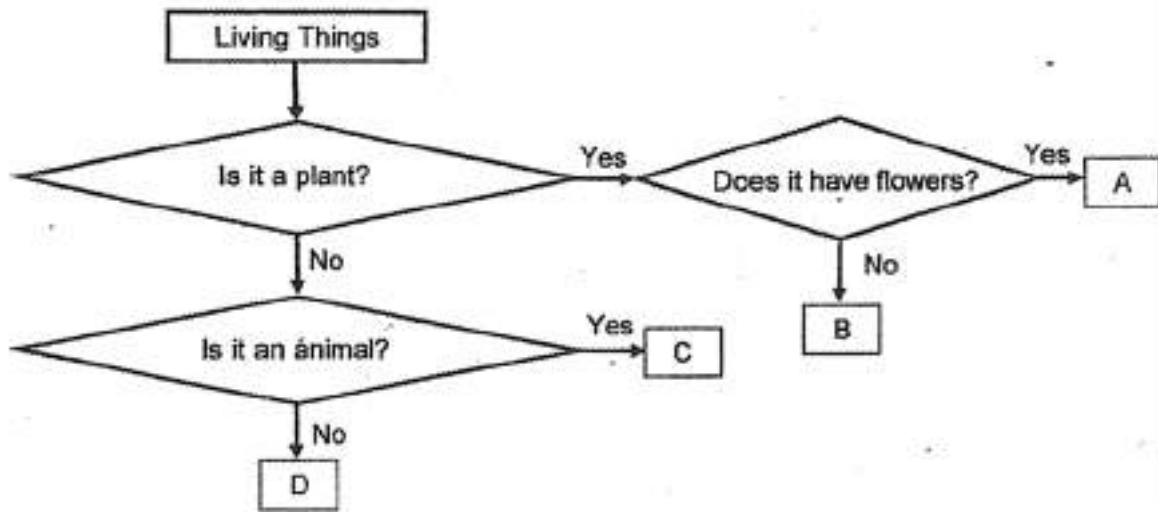

Which one of the following correctly represents A, B, C and D?

	A	B	C	D
(1)	Rose plant	Yeast	Bird	Mould
(2)	Yeast	Mould	Fern	Rose plant
(3)	Fern	Rose plant	Yeast	Mould
(4)	Rose plant	Fern	Bird	Yeast

- A) 1
- B) 2
- C) 3
- D) 4

The materials used in an experiment are shown below. Objects A, B, C and D are put into the basin of water.

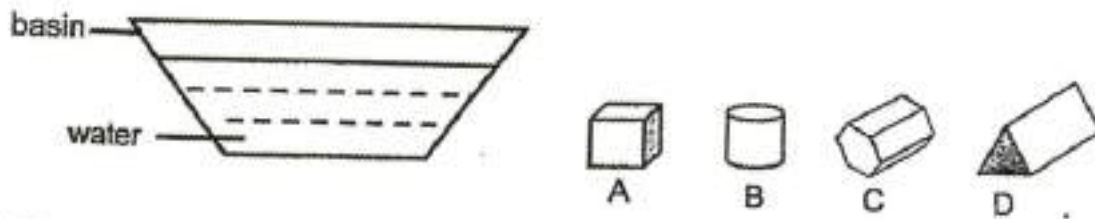

The observations are recorded in the table below.

Object	Stay at the bottom of the basin	Stay on the water surface
A	Yes	No
B	No	Yes
C	No	Yes
D	Yes	No

What is the aim of the experiment?

- A) To find out the mass of the objects
- B) To find out the volume of the objects
- C) To find out if the objects float or sink
- D) To find out if the objects are waterproof

The diagram below shows two bumper cars. The fun of riding the bumper cars is to hit other bumper cars so that the cars bounce off from one another.

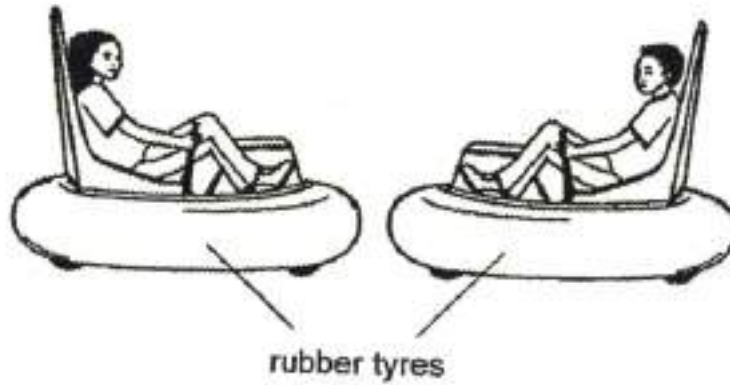

Which two properties must the tyres have to prevent damages to the cars?

- A) strong and flexible
- B) strong and waterproof
- C) flexible and waterproof
- D) flexible and transparent

5. Cassandra bought two identical pots of plants. She placed them in the garden. After a few days, she observed that Plant X grew healthily but Plant Y died.



Plant X



Plant Y

The table below shows the living conditions which the plants were exposed to.

	Type of soil	Volume of water (ml)	Volume of fertiliser (ml)	Location of the pot
Plant X	Garden soil	50	10	In direct sunlight
Plant Y	Garden soil	0	10	In direct sunlight

Which one of the following can Cassandra conclude based on her observations?

-
- A) plants need water to survive
- B) plants need sunlight to make food
- C) plant x grew healthily in the sun but not plant y
- D) plant y could not grow healthily with the addition of fertiliser

The picture below shows a food conveyor belt sending food to customers.



Which one of the systems in our body has the same function as the food conveyor belt?

-
- A) skeletal system
 - B) muscular system
 - C) circulatory system
 - D) respiratory system

Andy used a bar magnet to repeatedly stroke an iron nail as shown below.

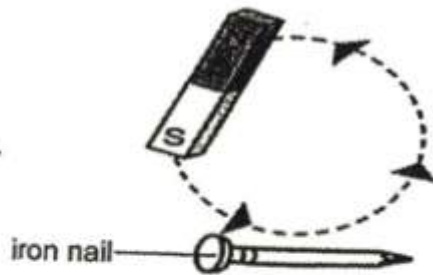

Both the magnetised iron nail and the compass were each freely floating on a piece of foam in a basin of water. The diagram below shows the directions of the magnetised iron nail and the compass when they came to a rest.



Next, he placed the magnetised iron nail next to the bar magnet. Which of the following observations are correct?

	Setup	attract	repel
A		Yes	No
B		Yes	No
C		No	Yes
D		No	Yes

- A) A and B only
- B) A and C only
- C) B and D only
- D) C and D only

Ivanna made 3 electromagnets, X, Y and Z, using similar wires, batteries and different number of coils as shown below.

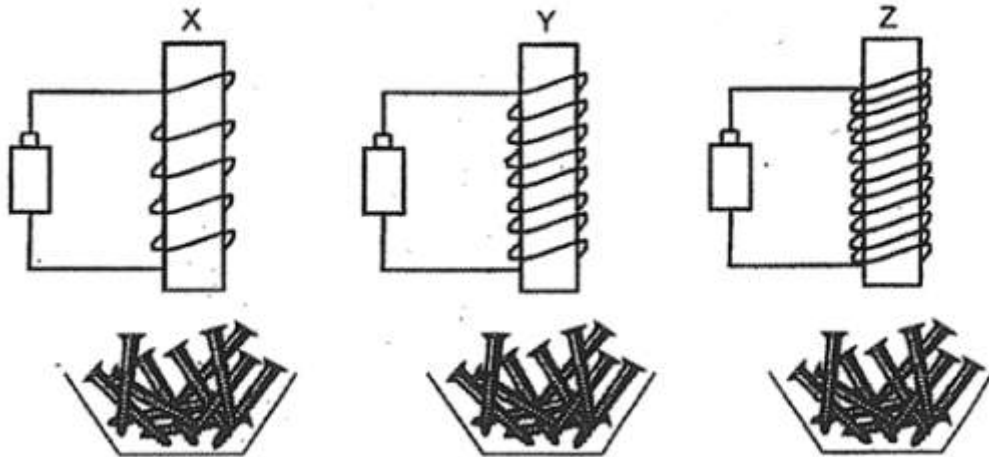

She placed each electromagnet 5 cm away from the container filled with iron nails. She observed the number of iron nails attracted by the 3 electromagnets. However, she forgot to record the number of iron nails attracted by them.

Which set of data most likely shows the observations that Ivanna made?

(1)

Electromagnet	Number of iron nails attracted
X	1
Y	2
Z	4

(2)

Electromagnet	Number of iron nails attracted
X	1
Y	1
Z	1

(3)

Electromagnet	Number of iron nails attracted
X	4
Y	1
Z	2

(4)

Electromagnet	Number of iron nails attracted
X	4
Y	2
Z	1

- A) 1
- B) 2
- C) 3
- D) 4

Torches A, B, C and D were switched on. Only Screen W did not have a shadow.

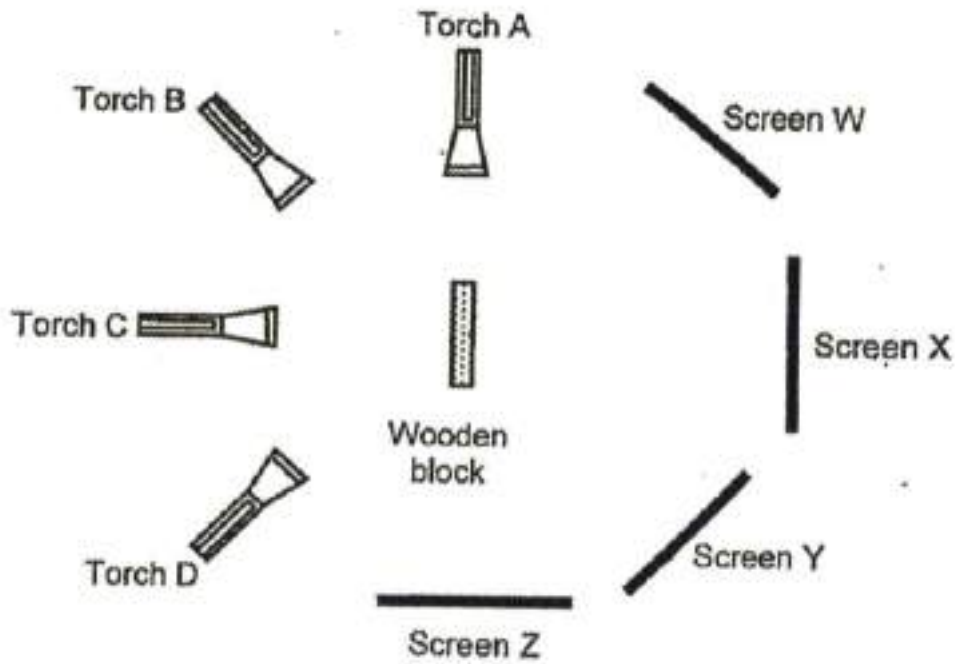

Which torch was not working?

- A) A
- B) B
- C) C
- D) D

James was boiling some soup in a pot over a campfire. He left the metal spoon in the hot boiling soup for some time.



The metal spoon became hotter after a while.
Which one of the following explains this?

-
- A) the pot lost heat to the hot soup
 - B) the spoon lost heat to the hot soup
 - C) the hot soup gained heat from the spoon
 - D) the spoon gained heat from the hot soup

Jason poured some hot coffee into a flask and placed it in a basin of cold water as shown in the diagram below.

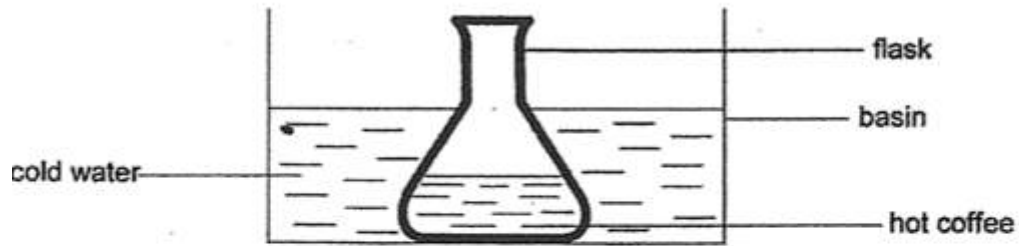

He then plotted a graph to show the temperature of the hot coffee and cold water over a period of time.

Which one of the graphs below shows the correct change in temperature of the hot coffee and the cold water after some time?

Key:

Cold water
Hot coffee	————
Room temperature	- - - - -

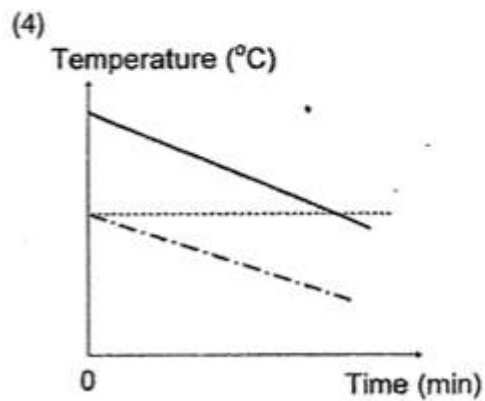
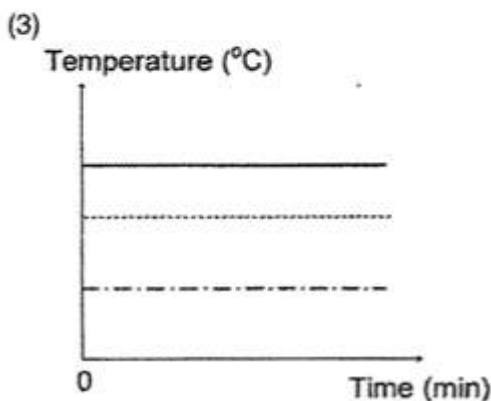
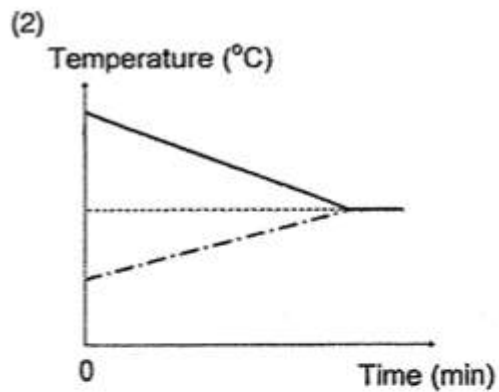
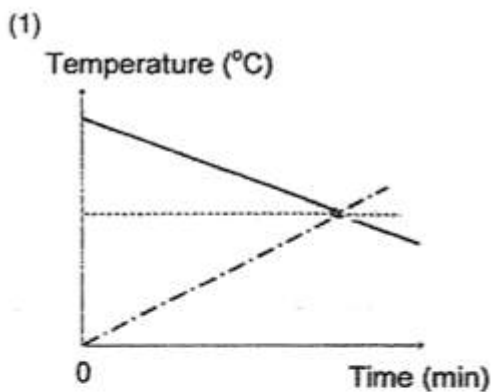

- A) 1
- B) 2
- C) 3
- D) 4

Alvin wants to investigate which material is the best conductor of heat. He set up the experiment as shown below. Four metal rods, A, B, C and D, were heated on one end to melt the drop of wax that was placed on the other end of each rod.

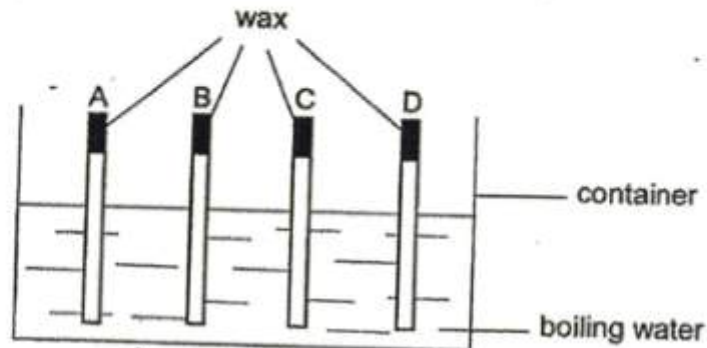

The time taken for the drop of wax to melt completely was recorded in the table below.

Rod	Time taken for the drop of wax to melt completely (s)
A	90
B	65
C	150
D	200

- A Rod B is the best conductor of heat.
 B The four rods conduct heat at different rates.
 C Rod C is a better conductor of heat than rod A.

Which statement(s) is/are correct based on the experiment above?

- A) A only
 B) B only
 C) A and B only
 D) B and C only

Which of the following shows the correct life cycle of a flowering plant?

(1)

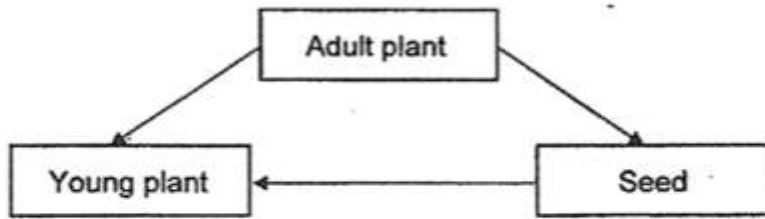

(2)

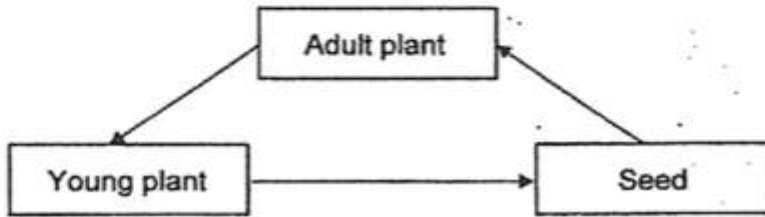

(3)

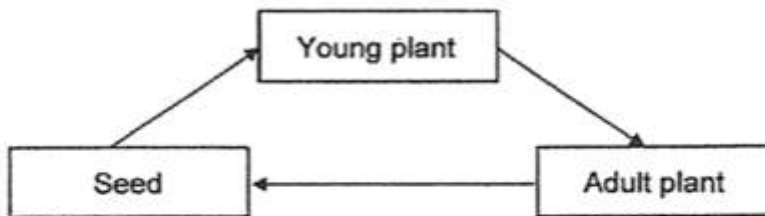

(4)

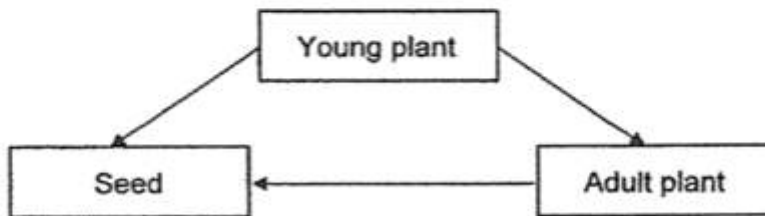

- A) 1
- B) 2
- C) 3
- D) 4

Question 24 of 62

Primary 4 Science (Term 3) 2 pts

Which of the following statements about the life cycles of cockroach and mosquito are correct?

- A The eggs of the mosquito are laid in water
- B The eggs of the cockroach are laid on land
- C The cockroach and the mosquito have a 3-stages life cycle
- D The young of the cockroach and mosquito do not look like the adult

-
- A) A and B only
 - B) C and D only
 - C) A, B and C only
 - D) B, C and D only

Question 25 of 62

Primary 4 Science (Term 3) 2 pts

- The diagram below shows a 500 cm³ jar containing 200 cm³ of water and a pump containing 150 cm³ of air. When the plunger is pushed all the way down, the air in the pump goes into the jar.

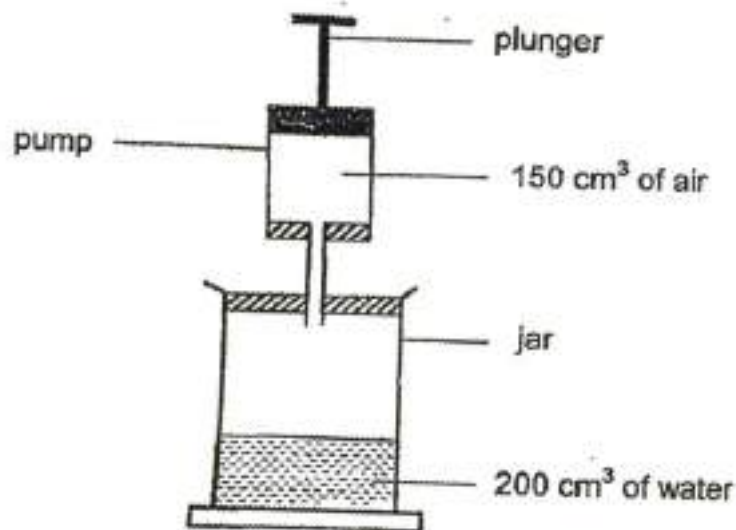

What is the volume of the air in the jar after the plunger is pushed down once?

-
- A) 150cm³
 - B) 300cm³
 - C) 450cm³
 - D) 500cm³

The diagram below illustrates a water cycle.

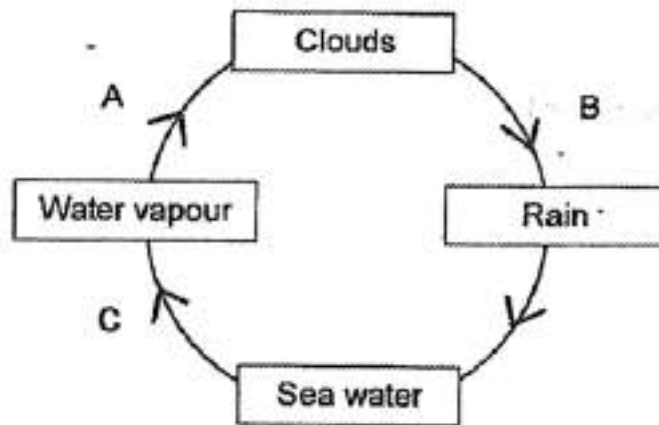

Which of the following letters represent evaporation and condensation?

	Evaporation	Condensation
(1)	A	B
(2)	B	A
(3)	C	B
(4)	C	A

- A) 1
- B) 2
- C) 3
- D) 4

Question 27 of 62

Mei Ling wanted to cut down on water consumption in her house. Which of the following actions allow her to save water at home?

- A Taking shorter showers
- B Brushing teeth with a mug
- C Washing a car with a hose
- D Using water from laundry to wash the toilets

- A) A and B only
- B) C and D only
- C) A, B and C only
- D) A, B and D only

3. All the beakers below with water at different temperature were placed in a room with a temperature of 25°C.

Which one of the following diagrams shows the likely results after ten minutes?

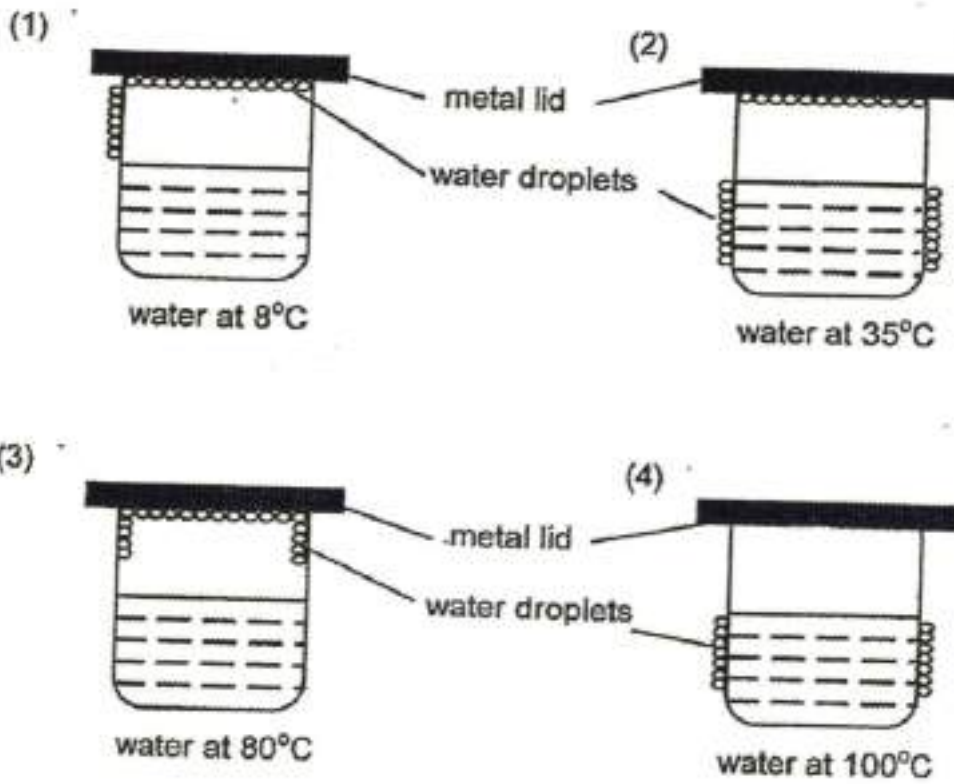

- A) 1
- B) 2
- C) 3
- D) 4

Question 29 of 62

Primary 4 Science (Term 3) 1 pt

Fill in the blanks in the table with names of broad groups of living things or the body coverings for the group. [4]

Group	Body coverings
(a)	Hairs

Question 30 of 62

Primary 4 Science (Term 3) 1 pt

(b)	Dry skin, with scales
-----	-----------------------

Question 31 of 62

Primary 4 Science (Term 3) 1 pt

(c) Fish	
----------	--

Question 32 of 62

Primary 4 Science (Term 3) 1 pt

(d) Amphibian	
---------------	--

Question 33 of 62

Primary 4 Science (Term 3)

1 pt

Susan placed magnet A near a rod made of an unknown material. The rod moves towards the magnet as shown by the arrow below.

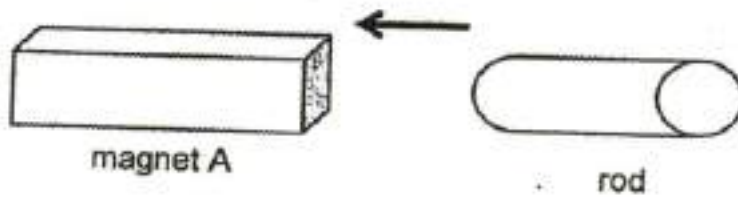

Magnet A exerts a _____ on the rod.

[1]**Question 34 of 62**

Primary 4 Science (Term 3)

1 pt

The rod is made of _____

- A) plastic
- B) steel
- C) aluminium

Question 35 of 62

Primary 4 Science (Term 3)

1 pt

Susan's observation shows that the rod is a _____ material

- A) hard
- B) magnetic
- C) strong

Susan then placed magnet A with its North-pole facing another magnet B. Magnet B moves away from magnet A as shown by the arrow below.

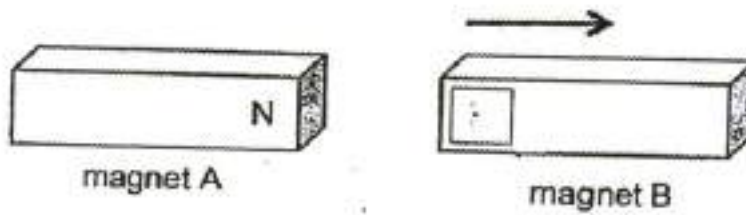

Label the pole of magnet B in the box above.

[1]

The diagram below shows how Siti sees the ball.

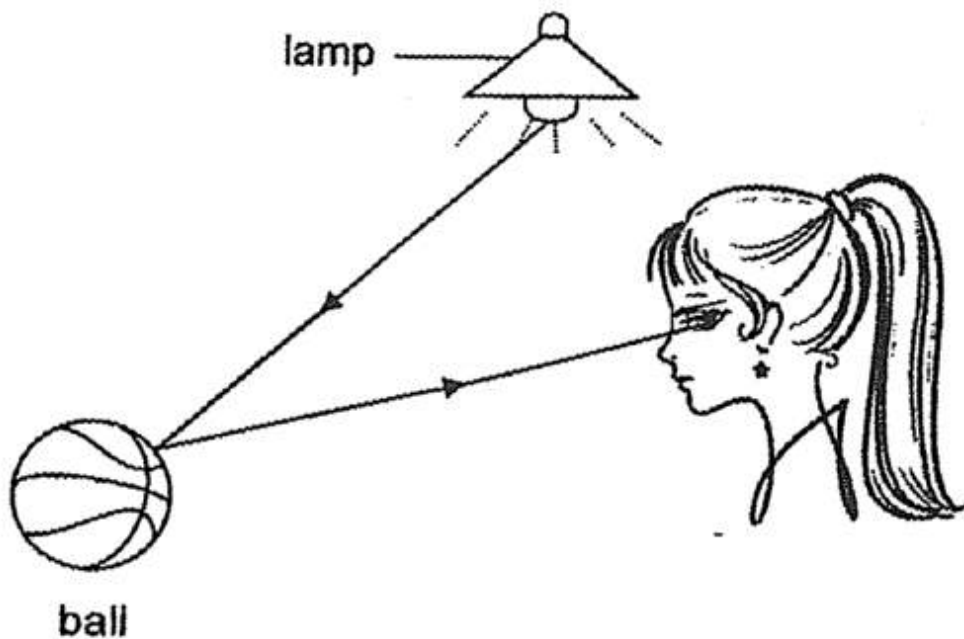

Light travels in a _____ line.

Question 38 of 62

Primary 4 Science (Term 3) 2 pts

The light from the ___ is reflected by the ___ and enters Siti's eye.

____, ____

Question 39 of 62

Primary 4 Science (Term 3) 1 pt

Henry boiled some soup in the pot as shown below.

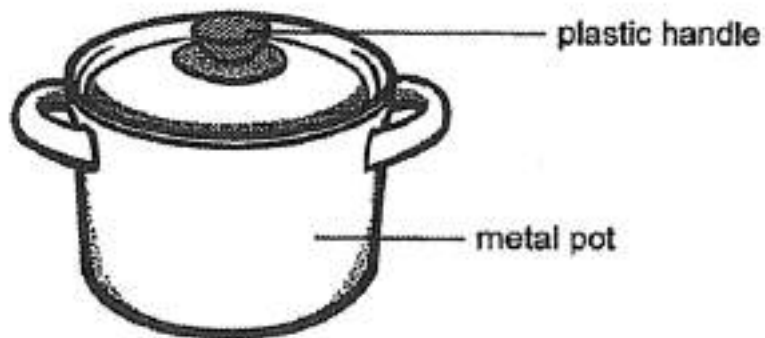

The handle is made of plastic because it is a _____ conductor of heat. [1]

Question 40 of 62

Primary 4 Science (Term 3) 1 pt

The pot is made of metal because it is a ___ conductor of heat.

Jason compares the mass of three fruits.

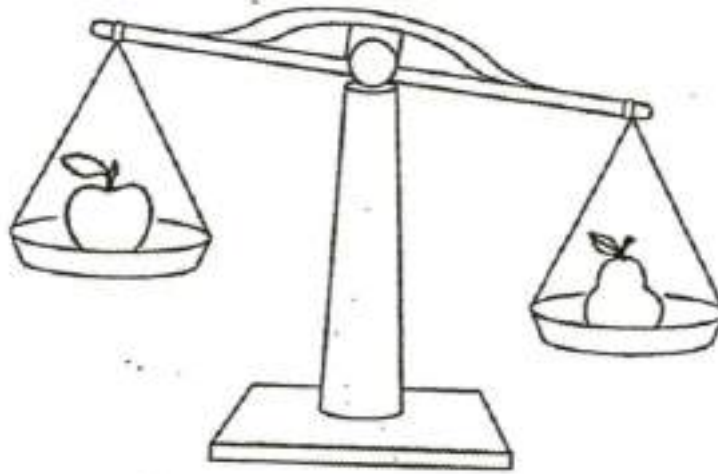

Study the diagram above. Put a tick (✓) in the box for the correct comparison.

- A) The apple is lighter than the pear
- B) The apple is heavier than the pear
- C) The apple has the same mass as the pear

[1]



Study the diagram above. Put a tick (✓) in the box for the correct comparison.

- A) The apple is lighter than the grapes
- B) The apple is heavier than the grapes
- C) The apple has the same mass as the grapes

If we were to compare the mass of the pear and grapes, the mass of the pear would be ____ than the mass of the grapes.

The diagram below shows the set-up of an experiment to find out which material soaks up the most amount of water. Materials C and D were hung on a string such that the tips of both materials were touching the coloured water.

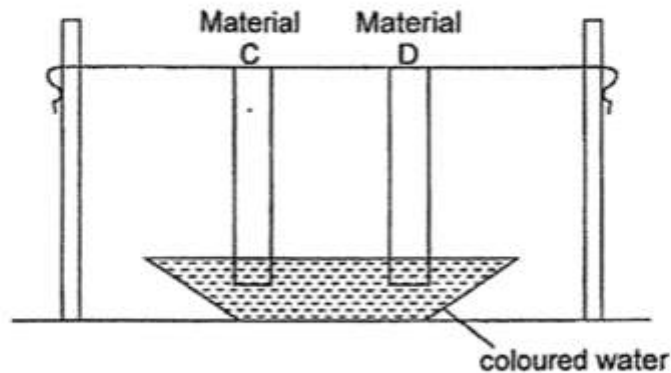

After 10 minutes, both materials were removed. The length of each of the material that was stained with coloured water was measured and recorded in the table below.

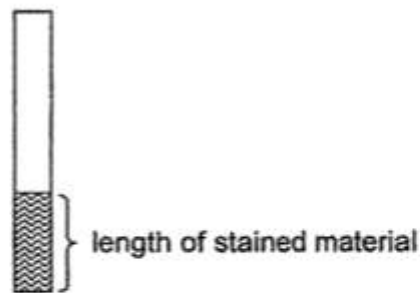

Material	Length of stained material (cm)
C	0
D	3

Choose

2 option to show the two variables that must be kept the same

- A) thickness of the materials
- B) length of the stained material
- C) length of the material put into the coloured water

Materials C and D of the same size were each put over a beaker as shown in the diagram below. 20 cm³ of coloured water was poured onto both materials.

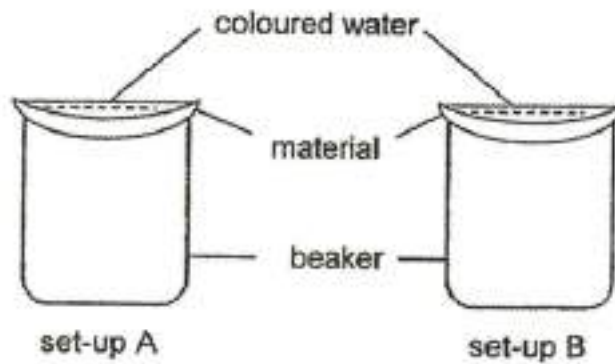

After 15 minutes, the amount of water left on the material was measured and recorded in the table as shown below.

Set-up	Amount of water left on material (cm ³)
A	0
B	20

Which set-up is material C placed on? Explain your answer.

[2]

Study the diagram below carefully.

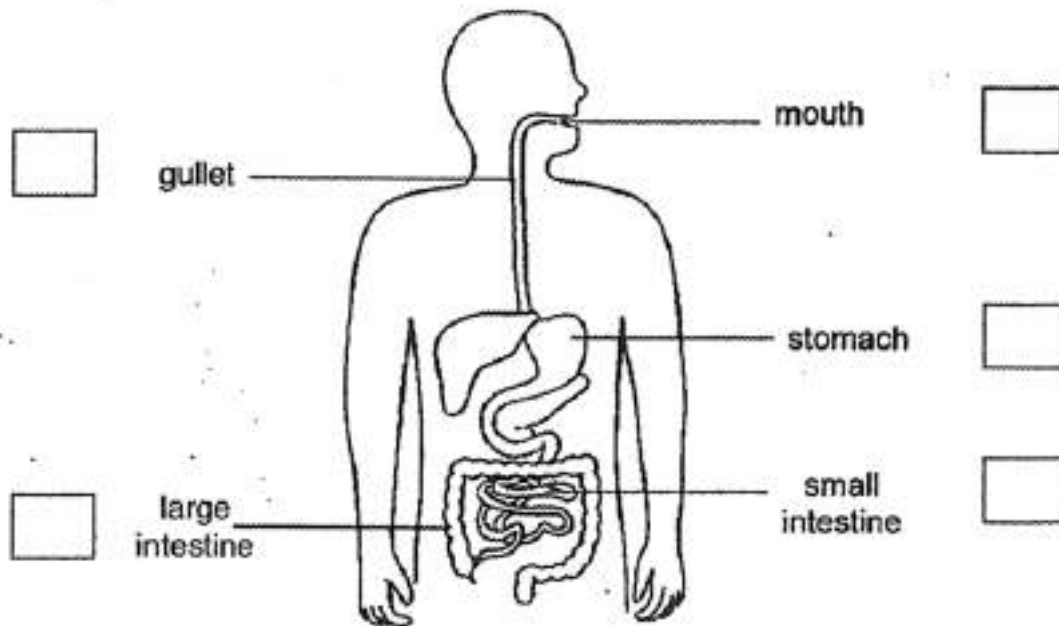

Put a tick (✓) in the boxes to show two parts of the human digestive system where no digestion will take place. [2]

- A) gullet
- B) mouth
- C) stomach
- D) large intestine
- E) small intestine

The graph below shows the amount of digested and undigested food when it first enters each part of the digestive system. The food moves from A to E.

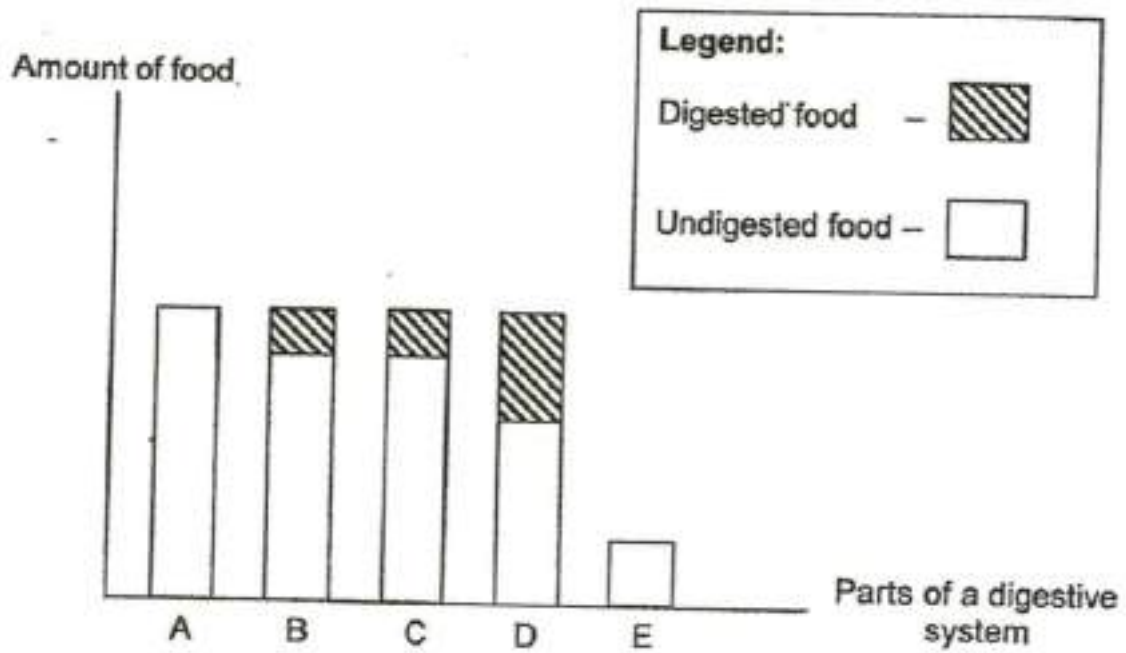

From the information in the graph, which part, A, B, C, D or E, represents the small intestine? Give two observations to support your answer. [2]

The diagram below shows the set-up to find out the amount of light that will pass through material X. The experiment was conducted in a dark room.

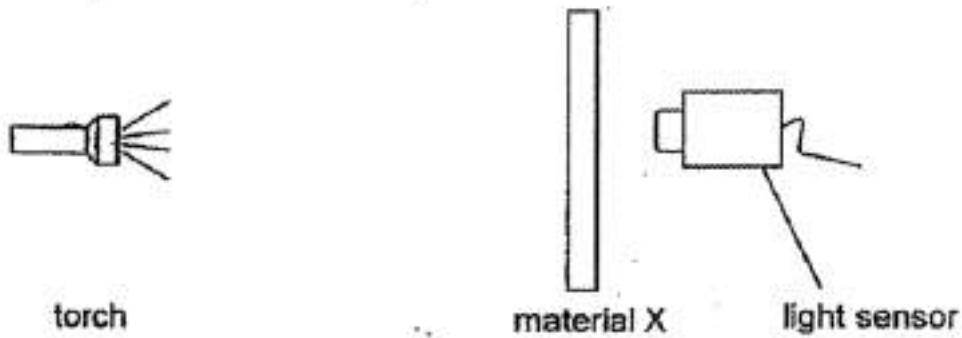

The results are shown in the table below.

Material	Amount of light shown on light sensor (lux)		
	1 st try	2 nd try	Average
X	0	0	0

State the property of material X based on the results shown in the table above. [1]

Two different shapes were cut out from material X of different colour.

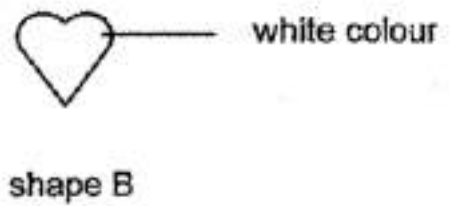
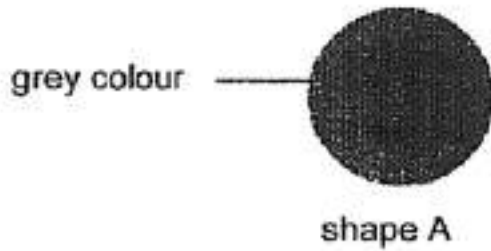

Shapes A and B were glued together to form Object C as shown below.



A light source was shone on object C and a shadow was formed on the screen.

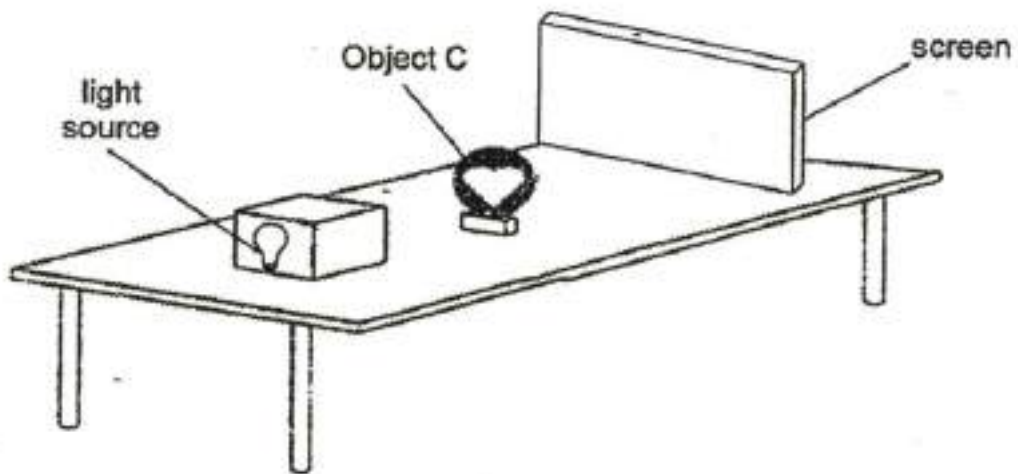

Put a tick (✓) in one of the boxes below to show the shadow of Object C that will be formed on the screen. [1]

A)



B)



Question 50 of 62

Primary 4 Science (Term 3) 1 pt

- Hazlinah conducted an experiment using four containers made of different materials, A, B, C and D, as shown below. She placed four identical cups containing cold water at 2°C in the containers and placed these containers in the science laboratory.

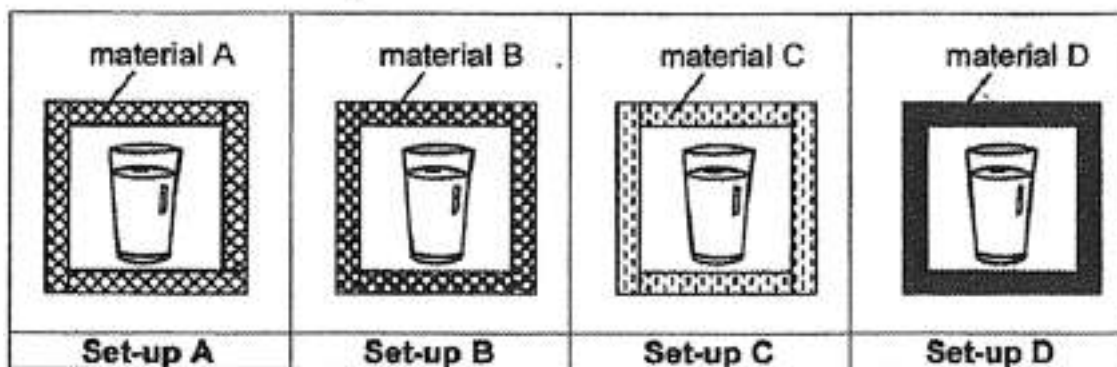

After 20 minutes, she recorded the temperature of water in each cup with a thermometer. The results are shown in the table below.

Material	Temperature of water (°C)	
	At the start of experiment	At the end of experiment
A	2	20
B	2	5
C	2	14
D	2	8

Arrange the materials based on their heat conductivity starting from the poorest heat conductor to the best heat conductor.

Question 51 of 62

Primary 4 Science (Term 3) 0 pts

Hazlinah wants to hold a cup filled with hot tea without burning her hand. Which one of the materials A,B,C or D should the cup be made of? Explain your answer.

The diagrams below show the life cycles of a butterfly and a beetle.

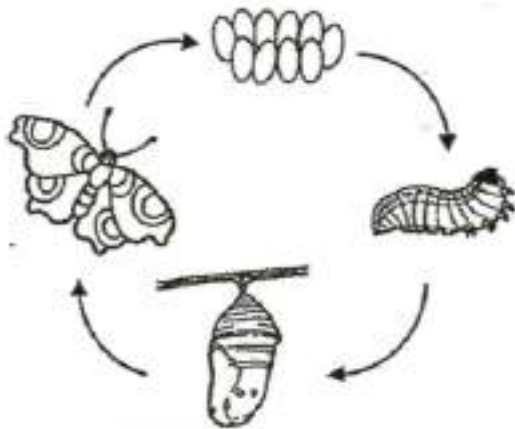

Life cycle of a butterfly

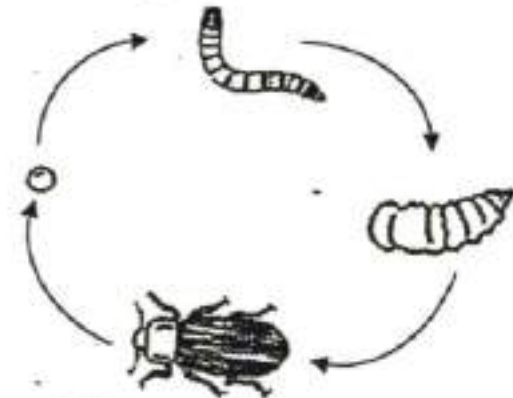

Life cycle of a beetle

State one similarity between the life cycle of the butterfly and the beetle. [1]
(Do not name the stages in the life cycles.)

Which group of animals does the two living things belong to?

State one characteristic of the group of animals mentioned in part (b).

State one characteristic of living things that enables its own kind to continue to exist.

Jessie prepared two identical syringes and filled each of them with a different type of matter, Q and R.

The nozzle is sealed at each end of the syringe. Then, she pushed the plunger for the two syringes, one at a time, as shown below.



She recorded the distance moved by the plunger for each syringe in the table below.

Distance moved by plunger (cm)	
Q	R
0	0.6

If Jessie had used **air** and **water** in her experiment, identify Q and R

Q: _____

R: _____

Predict the distance moved by the plunger when cotton wool is used

Question 59 of 62

Primary 4 Science (Term 3) 0 pts

Explain your answer for cotton wool

Question 60 of 62

Primary 4 Science (Term 3) 0 pts

Three identical towels, A, B and C, were soaked with 100 ml of water and the towels were then folded along the dotted lines as shown in the diagram below.



Towel A



Towel B



Towel C

They were placed under the Sun in the open field. The time taken for each towel to dry completely was recorded in the table below.

	Towel A	Towel B	Towel C
Number of folds	1	2	4
Time taken to dry (min)	20	50	120

What is the independent variable (changed variable) in this experiment? [1]

Question 61 of 62

Primary 4 Science (Term 3) 0 pts

Based on the experiment, state the relationship between the number of folds of the towels and the time taken for the towels to dry.

Explain why Towel A took the shortest time to dry
